

Specifications

Type	PW-100B
Film Material	BOPP
Structure	Reciprocating
Packing Speed	10-60PPM
Packing Size MAX	H: 130 mm
	W: 280 mm
Packing Film Size MAX	W: 580 mm
	Φ: 330 mm
Packing Film Speed MAX	15 m/min
Length Cutting Size Range	230-900mm
Dimension	5130 (L)*1052(W)*1679(H)
PowerSupply	AC 220V 50/60HZ 5.0 KW



PW-100

High-speed Pillow Type Packing Machine

External Dimension

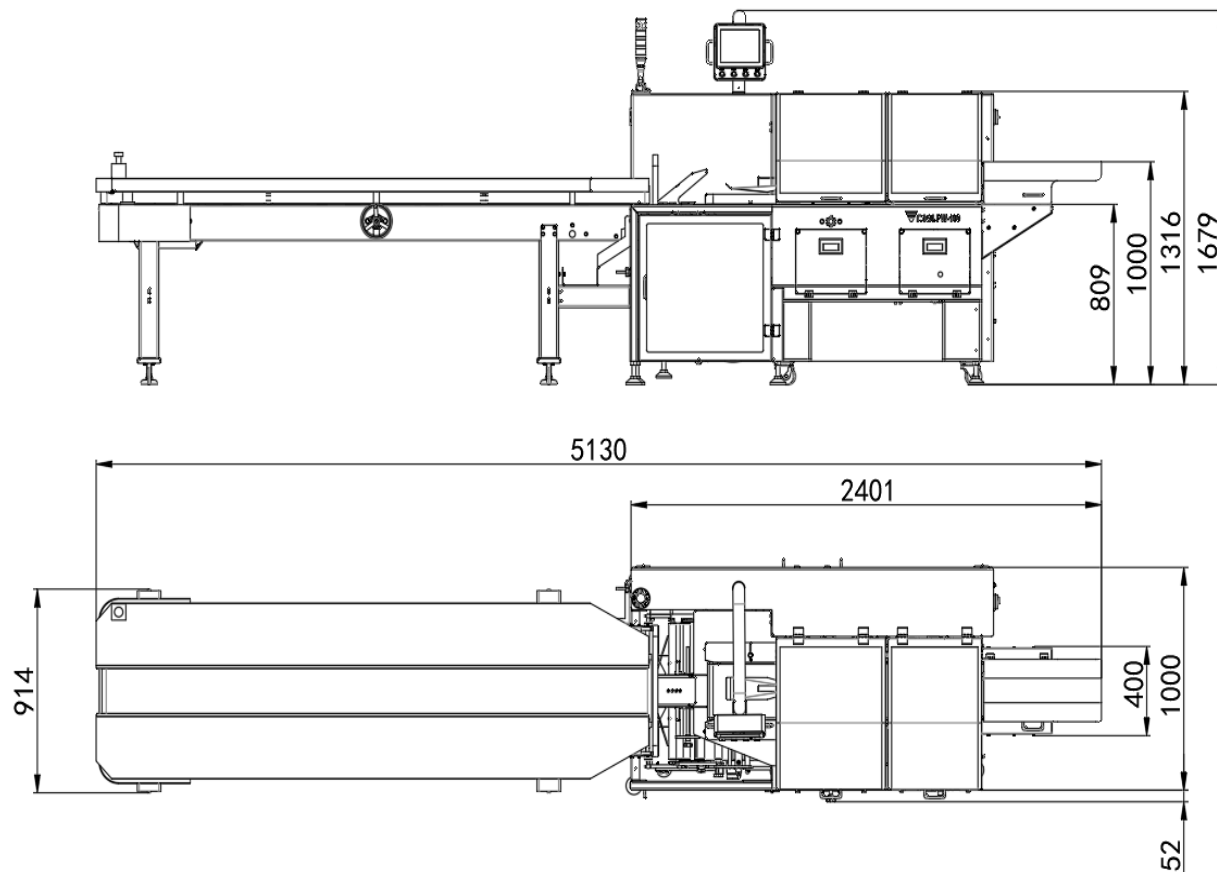

* Specifications are subject to change without prior notice

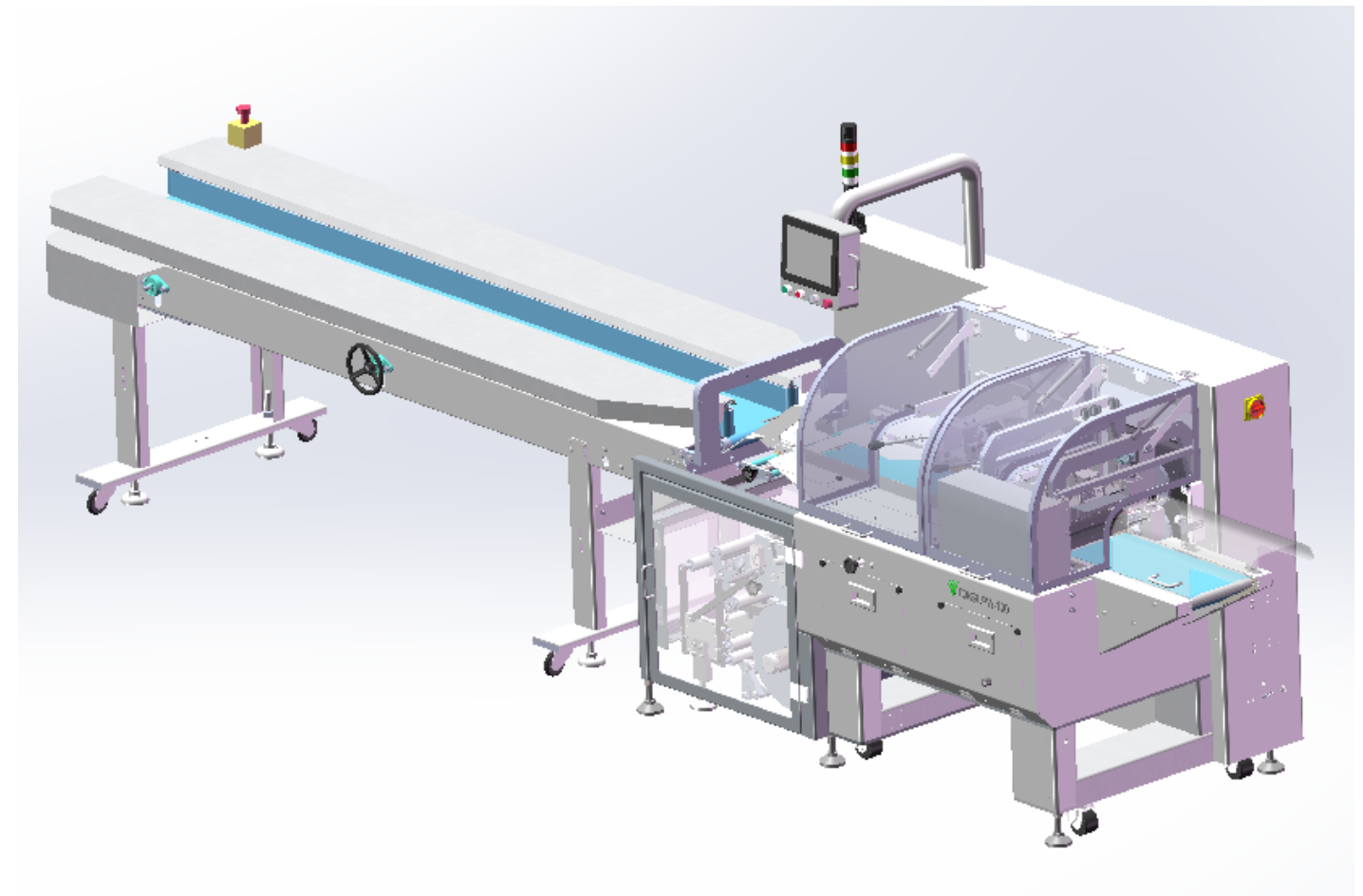

Shanghai Teraoka Electronic CO.,Ltd

Add: Ting Lin Industry Development Zone, Jin Shan County, Shanghai, China

Tel: +86 21 57234888

Fax: +86 21 57234891

Code: 201505

Website: www.digisystem.com

Searching for a New Balance