



SCG series

High-performance Check Weigher



SPECIFICATIONS

SCG Series Check Weigher Specifications

Type		6kg	15kg	Special Type
Accuracy Class	X(III), Y(a)	X(III), Y(a)	X(III), Y(a)	Customized as per special request
Display	8.4" LCD	8.4" LCD	8.4" LCD	
Maximum capacity	3000g	6000g	15000g	
Belt Length A-A(mm)	200/300	200/300	300/400	
Belt Length B-B(mm)	150/200	150/200	200/250	
Loadcell	20kg	20kg	20kg	
Belt Convey Speed	20m/min	20m/min	20m/min	
Actual scale interval	1g	2g	5g	
Verification scale interval	1g	2g	5g	
Adjustable Height	±50mm	±50mm	±50mm	
Operating Environment	-10-40°C Non-condensing			
Power Supply	230VAC, 50/60HZ			

DIMENSION(mm)

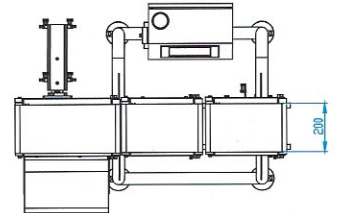
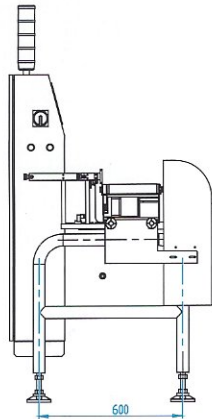
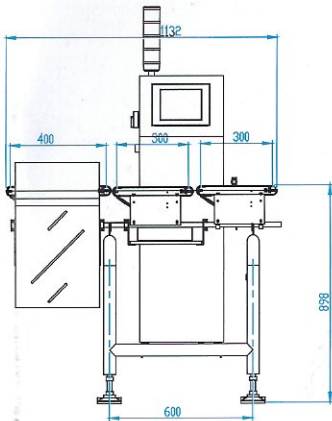

REJECTER OPTIONS

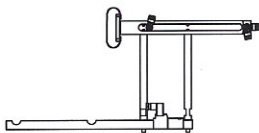

Pushing rejecter

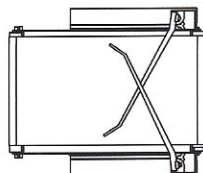

Rod Swing Rejecter

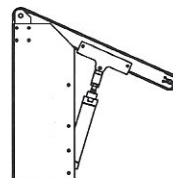

Drop Down Rejecter

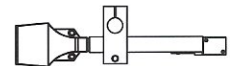

Air-sweeping Rejecter

*Specifications are subject to change without prior notice.

SHANGHAI TERAOKA ELECTRONIC Co., Ltd.

TINGLIN INDUSTRY DEVELOPMENTAL ZONE,
JINSHAN COUNTY, SHANGHAI 201505

TEL: +86-21-57234888

FAX: +86-21-57233049

<http://www.digisystem.com.cn>